

737 NG POWER SOURCES OVERVIEW

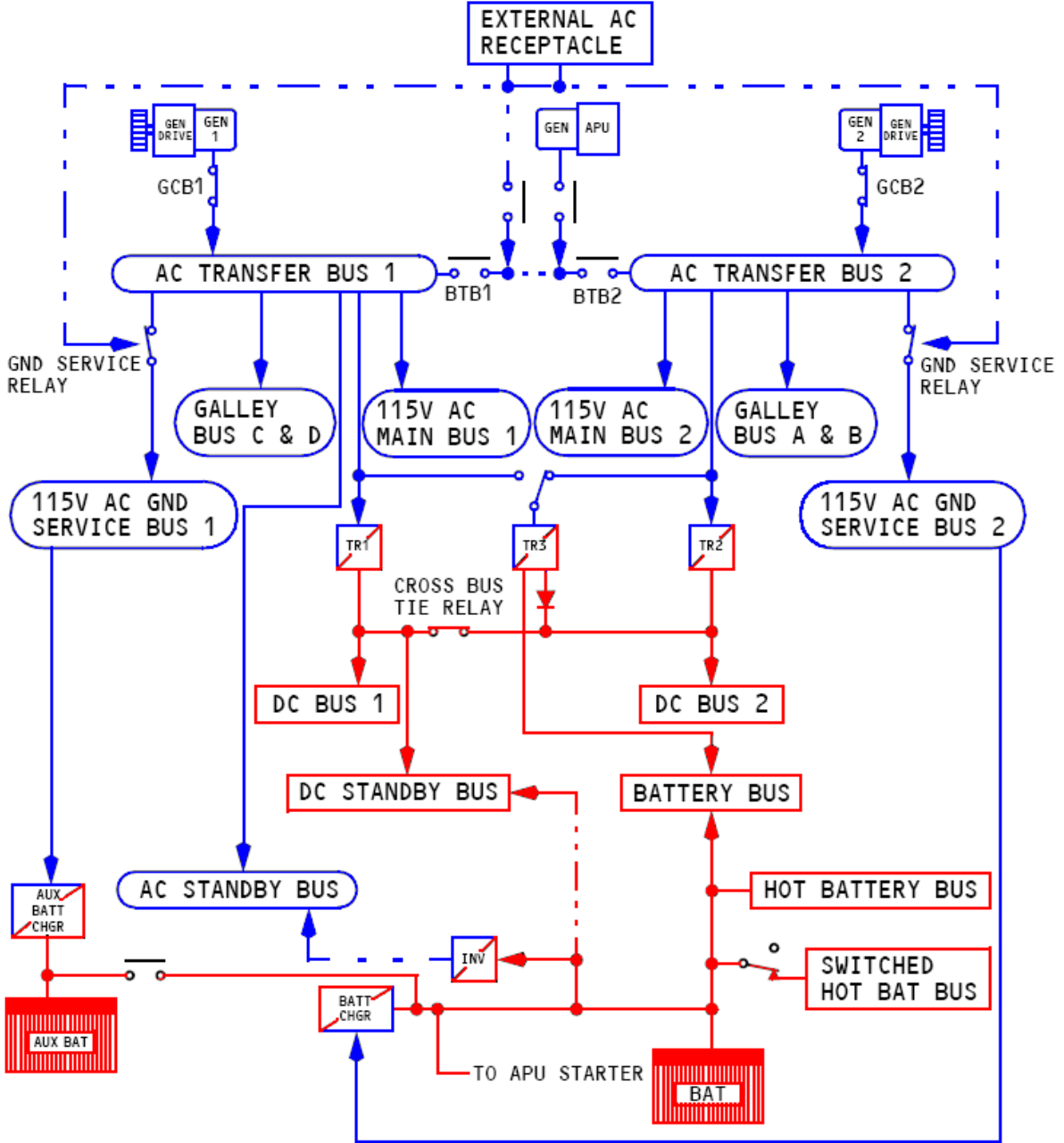

AIRPLANE CONFIGURATION - IN FLIGHT
BATTERY SWITCH - ON
STANDBY POWER SWITCH - AUTO
BUS TRANSFER SWITCH - AUTO
ENGINE GENERATOR CONNECTED TO RELATED BUS

B737NG POWER SOURCES

115 VAC TRANSFER BUS 1

Normal power – IDG 1.
Alternate power – XFR bus 2 via BTB's.

- **28 VAC XFR BUS**
- APU START CONVERTER
- B SYS ELEC HYDR PUMP
- BOOST PUMP TANK 1 FWD
- BOOST PUMP TANK 2 AFT
- EQUIP COOL SUPPLY FAN ALT
- **GALLEY BUS C & D**
- **GROUND SERVICE BUS 1**
- MAIN BUS 1
- MIDU
- TEMP CONT 35 DEG L
- TEMP CONTL
- TEMP CONT MAN
- TRU 1
- TRU 3 ALT
- VACUUM WASTE BLOWER
- **XFR BUS 1 SEC 1**
- **XFR BUS 1 SEC 2**

- YAW DAMPER INDICATION

115 VAC TRANSFER BUS 1 -Sect 2

Power – XFR bus 1

- **AC STBY BUS**
- ACARS MU AC
- AIRCO PACK CONT LEFT AC
- BLEED AIR ISLN VALVE
- CMU 1 AC
- PRINTER
- RAM AIR MOD LEFT
- TEMP CONT VALVE CLOSE L
- TEMP VALVE/FAN CONT AFT CABIN
- WINDOW HEAT POWER L1, L3, L4 & L5
- WINDOW HEAT POWER R SIDE

115 VAC TRANSFER BUS 1 - Sect 1

Power – XFR bus 1

- **28 VAC XFR BUS 1 SEC 1**
- AFCS A SNSR EXC AC
- ALPHA VANE HEATER LEFT
- ANTI COLLISION LIGHT RED
- ANTI COLLISION LIGHT WHITE
- BOOST PUMP CTR TANK LEFT
- CAPT PITOT HEATER
- DATA LOADER
- ELEVATOR PITOT LEFT
- ENG 1 LEFT IGNITION
- ENG 1 ALT POWER CHAN B
- ENG 1 ALT PWR CHAN A
- FLIGHT REC AC
- GROUND PROX WARNING
- HF 1
- L FIXED LANDING LIGHT
- MACH TRIM A AC
- R RETRACT ABLE LANDING LIGHT
- RADIO ALT 1
- STAB TRIM AFCS
- TCAS
- TEMP PROBE HEATER
- WINDOW HEAT CONTROL L FRONT AC
- WINDOW HEAT CONTROL L SIDE AC
- WING ANTI ICE VALVE

115 VAC TRANSFER BUS 2

Normal power – IDG 2
Alternate power – XFR bus 1 via BTB's

- **28 VAC XFRBUS 2**
- A SYS ELEC HYDR PUMP
- AIRCO PACK CONT RIGHT AC
- BOOST PUMP CTR TANK RIGHT
- BOOST PUMP TANK 1 AFT
- BOOST PUMP TANK 2 FWD
- EQUIP COOL EXH FAN ALT
- EQUIPCOOL SPLY FAN NORM
- **GALLEY BUS A & B**
- **GROUND SERVICE BUS 2**
- **MAIN BUS2**
- STBY HYDR PUMP
- TEMP CONT VALVE CLOSE R
- TEMP VALVE/FAN CONT FLT DECK
- TEMP VALVE/FAN CONT FWD CABIN
- TRU 2
- TRU 3
- **XFR BUS 2 SEC 1**
- **XFR BUS 2 SEC2**

B737NG POWER SOURCES

115 VAC TRANSFER BUS 2 - Sect 1

Power – XFR bus 2

- ALPHA VANE HEATER RIGHT
- AUX PITOT HEATER
- ELEVATOR PITOT RIGHT
- FO'S PITOT HEATER
- HEAD UP GUIDANCE DEU ALTN AC
- L RETRACTABLE LANDING LIGHT
- R FIXED LANDING LIGHT
- VOICE RECORDER
- WINDOW HEAT CONTROL L SIDE AC
- WINDOW HEAT CONTROL R FRONT AC

- RUNWAY TURN OFF LIGHT LEFT
- TAXI LIGHT
- YAW DAMPER AC

115 VAC MAIN BUS 1

Power – XFR bus 1

- DOOR AREA HTR AFT
- DOOR AREA HTR FWD
- DRAIN HEATERS
- DRAIN MAST HEATER AIR
- HOSE HEATERS
- LAV A, D & E WATER HEATER
- LOGO LIGHT
- RECIRC FAN LEFT
- WATER COMPRESSOR

115 VAC TRANSFER BUS 2 - Sect 2

Power – XFR bus 2

- 115 VAC XFR BUS 2 INDICATION
- **28 VAC XFR BUS 2 SEC 2**
- ADF 2
- ADIRU R AC
- AFCS B SNSR EXC AC
- AIL TRIM CONTROL
- ATC 2
- BLEED AIR PRESS INDICATION
- DME 2
- ENG 2 LEFT IGNITION
- ENG 2 ALT POWER CHAN B
- ENG 2 ALT PWR CHAN A
- ENG VIB MON
- FLOOD LIGHT CONTROL

28 VAC TRANSFER BUS 2

Power – XFR bus 2 (stepdown XFR)

- ADIRU R EXC
- CAPT AFT ELEX PNL LIGHT
- CONTROL STAND LIGHT
- ELEX PANEL LIGHT FWD
- ELEX PANEL LT
- FO'S AFT ELEX PNL LIGHT
- FO'S INSTRUMENT LIGHTS 28V PRI
- FUEL TEMP INDICATOR
- INSTR & CB PNL LIGHTS
- MAP& KIT LIGHT
- OBSERVERS READING LIGHT
- O'HEAD PNL LIGHT 5V SECONDARY
- O'HEAD PNL LIGHT 28V PRIMARY
- O'HEAD PNL LIGHT 28V SECONDARY
- POS/SKEW SENSOR & IND RIGHT
- PRESS CONTROL LCD LIGHTING
- READING LIGHTS RH
- RUDDER TRIM INDICATOR
- RUNWAY TURN OFF LIGHT RIGHT
- SMYD 2 SNSR EXC AC
- TE FLAP POS/SKEW SENSOR & IND L

28 VAC TRANSFER BUS 1

Power – XFR bus 1 (stepdown XFR)

- CAPT INSTRUMENT LIGHTS 28V PRI
- DRAIN MAST HEATERS GND
- FASTEN SEAT BELT SIGN LEFT
- FASTEN SEAT BELT SIGN RIGHT
- FLIGHT REC POS SENSORS
- LAV OCCUPIED SIGN
- NO SMOKING SIGN LEFT
- NO SMOKING SIGN RIGHT
- READING LIGHTS LH

B737NG POWER SOURCES

115 VAC MAIN BUS 2

Power – XFR bus 2

- EXT AUDIO
- MUX
- RECIRC FAN R
- VIDEO 1, 2, 3 & 4
- VIDEO CONT CENTER AC
- ZONAL DRYER

115 VAC STANDBY BUS

Normal power – XFR bus 1
Alternate power – Hot Bat bus

- 115V AC STBY BUS INDICATION
- **28 VAC STBY BUS**
- ADF 1
- ADIRU LAC
- ATC 1
- DME 1
- ENG 1 IGNITION RIGHT
- ENG 2 IGNITION RIGHT
- FLOOD LIGHT STBY
- FMC 1
- MCDU 1
- MMR 1
- NAV CONTR PANEL
- RMI
- SCU FAN POWER
- VOR/MKR BCN 1
- FMC COMP 2
- FWD AIRSTAIR ACTUATOR
- HF 2
- MACH TRIM B AC
- MCDU 2
- MMR 2
- NAV CONTR PANEL 2
- NOSE GEAR STEERING
- RADIO ALT 2
- RAM AIR MOD RIGHT
- RUDDER TRIM CONTROL
- STAB TRIM ACTUATOR
- TAPE REC AC
- TE FLAP ALT DRIVE
- TEMP CONT 35 DEG L
- TEMP CONT AUTO RIGHT
- VOR 2
- WEATHER RADAR RT
- WHEEL WELL & WING BODY O'HEAT
- WINDOW HEAT POWER L SIDE
- WINDOW HEAT POWER R1, R3, R4 & R5

28 VDC - BAT BUS - Sect 3

Power – Bat bus

- AIR/GND SYS 2
- ALT GEAR EXTEND SOLENOID
- ANTI SKID INBOARD
- AURAL WARNING
- CLOCK DISPLAY
- CROSS FEED VALVE
- DOME LIGHT WHITE
- ENG 1 HPSOV CON
- ENG 1 HPSOV IND
- ENG 2 HPSOV CON
- ENG 2 HPSOV MD
- FUEL QUANTITY TANK 2
- LANDING GEAR LATCH &PRESS WNG
- MASTER CAUTION ANN BAT
- MASTER CAUTION ANNUN CONT 1, 2, 3 & 4
- MASTER DIM &TEST CONTROL
- MASTER DIM BAT
- STBY COMPASS LIGHTING

28 VDC - SW HOT BAT BUS

Power – Battery (switch ON)

- ADIRU L DC
- ADIRU R DC
- AFCS A WARN LT (BAT)
- AFCS WARN LT(BAT)
- APU CONTROL
- APU GENERATOR CONTROL UNIT
- FWD AIRSTAIR CONTROL STANDBY
- FWD AIRSTAIR STANDBY DOOR ACTUATOR
- GENERATOR BUS PWR CONTROL UNIT
- PSEU ALTN
- SPAR VALVE INDICATION
- SWITCHED HOT BATTERY BUS INDICATION

B737NG POWER SOURCES

28 VDC - HOT BAT BUS

Power – Battery or Battery charger

- BAT/STBY SW POS IND
- CARGO FIRE EXT 1
- CARGO FIRE EXT 2
- CLOCK
- DC HOT BAT BUS INDICATION
- DEU 1 HOLDUP
- DEU2HOLDUP
- DUAL BATTERY REMOTE CONTROL
- ENTRY LIGHTS DIM
- EVAC SIGNAL
- FIRE EXTINGUISHER APU
- FIRE EXTINGUISHER L ALT
- FIRE EXTINGUISHER LEFT
- FIRE EXTINGUISHER R ALT
- FIRE EXTINGUISHER RIGHT
- FUEL SHUTOFF VALVES BUS
- FUELING CONTROL
- FUELING INDICATORS
- GND SERVICE CONTROL
- GND SERVICE DC HOT BATTERY
- PARKING BRAKE
- SPCU STBY
- TR 3 XFR RELAY CONT

- LAVATORY MIRROR LIGHT
- POSITION LIGHT LEFT
- POSITION LIGHT RIGHT
- WING LIGHT

28 VAC GROUND SERVICE BUS 1

Power – 115 VAC Ground service bus 1

- COMPARTMENT ACCESS LIGHT
- LIGHTS FWD ELECTRONIC RACK
- NIGHT LIGHT CONTROL
- THRESHOLD LIGHT
- WORK & THRESHOLD LIGHT

28 VDC GROUND SERVICE BUS

Normal power – DC bus 1

Alternate power – Hot BB

- AFT CARGO LOADER CONT
- CABIN UTIL RLY PWR
- ENTRY LIGHTS AUTO DIM
- EXHAUST FAN CONT NORMAL
- FWD CARGO LOADER CONT
- PSEU PRIMARY
- VACUUM WASTE
- WASTE WATER LINE HEATERS

28 VAC STANDBY BUS

Normal power – XFR bus 1

Alternate power – Hot BB via inverter

- ADIRU L EXC
- EMERGENCY PANEL LIGHT (via 5 VAC stepdown XFR)
- SMYD 1 SNSR EXC AC

28 VDC BUS 1

Normal power – TR1

Alternate power – TR2 or TR3

- AFCS A RUDDER DC
- APU FIRE SWITCH
- B SYS ELEC HYDR PUMP CONT
- BUS PWR CONTROL UNIT
- **DC BUS 1 SEC 1**
- **DC BUS 1 SEC 2**
- DC BUS 1 XFR
- **DC STBY BUS SEC 1**
- **DC STBY BUS SEC 2**
- ELEX PNL AFT CENTER
- GENERATOR 1 LOAD SHED
- MASTER DIM SEC 7
- MASTER DIM SECTION 1, 2, 3 & 4
- PACK CONT VALVE L ALT
- RAM AIR MOD CONT L
- SPCU NORMAL
- VACUUM WASTE CONT

115 VAC GROUND SERVICE BUS 1

Normal power – XFR bus 1 or external power when available

- 28V AC GND SERVICE BUS 1
- AFT CARGO LOADER DRIVE
- AUX BATTERY CHARGER
- CEILING LIGHT LEFT
- CEILING LIGHT RIGHT
- ENTRY LIGHT BRIGHT
- EQUIP COOL EXH FAN NORM
- FWD CARGO LOADER DRIVE
- **GND SERVICE BUS 1 SEC 1**

B737NG POWER SOURCES

- WATER DRAIN VALVE
- WATER QTY INDICATION

115 VAC GROUND SERVICE BUS 2

Normal power – XFR bus 2 or external power when available

- **28 VAC GND SERVICE BUS 2**
- BATTERY CHARGER
- GALLEY LIGHT
- SERVICE OUTLET
- VAC OUTLET AFT
- VAC OUTLET FWD
- WINDOW LIGHT LEFT
- WINDOW LIGHT RIGHT

28 VAC GROUND SERVICE BUS 2

Power – 115V AC Ground service bus 2

- AFT CARGO COMP LIGHT
- AIRCO COMP LIGHT
- FWD CARGO COMP LIGHT
- WHEEL WELL LIGHT
- WINDOW LTS BRT CONT

28 VDC BUS 2

Normally power – TR2
Alternate power – TR3 or TR1

- A SYS ELEC HYDR PUMP CONT
- AFCS B RUDDER DC
- AFCS INTLK 2
- APU GENERATOR CONTROL UNIT
- CAPT AUDIO
- CARGO LIGHT CONTROL
- **DC BUS 2 SEC 1**
- **DC BUS 2 SEC 2**
- DC BUS 2 XFR
- ENG 1 SPAR VALVE
- ENG 2 SPAR VALVE
- ENT AUDIO DC
- F/O'S AUDIO
- FORCE FIGHT MONITOR
- GENERATOR 2 LOAD SHED
- INTERPHONE AND WARNING
- MASTER DIM SECTION 5, 6, 7 & 8
- MIX VALVE POS IND
- OBERSERVERS AUDIO

- PACK CONT VALVE R ALT
- RAM AIR MOD CONT R
- RECIRC FAN CONT
- ZONAL DRYER CONT

28 VDC BUS 1 - Sect 1

Normal power – DC bus 1

- AFCS A ENGAGE INTLK
- AFCS A RUDDER DC (Cat IIIb)
- AUTO THROTTLE DC 1
- CABIN CREW CALL
- CARGO FIRE DETECTOR AFT A
- CARGO FIRE DETECTOR FWD A
- CHARGER L AFT
- CHARGER R AFT
- DOOR AREA HEAT CONT
- EMER EXIT LT CHARGER FWD
- ENG 1 COWL ANTI ICE VALVE
- ENG 1 RUN/PWR
- ENG 1 THRUST REVERSER IND
- FCC A DC
- FLIGHT RECORDER DC
- FMC BITE DC
- HEAD UP GUIDANCE CMPTR DC
- HEAD UP GUIDANCE CONT PNL DC
- LAV SMOKE
- LIGHT CONT
- LOW FLOW DETECT EXHAUST
- MACH TRIM A DC
- MCP DC 1
- PASSENGER SIGN CONTROL
- PAX CALL LEFT
- RECIRC FAN L CONT
- SELCAL
- TERRAIN DISPLAY
- WINDSHIELD WIPER LEFT
- YAW DAMPER 1 & 2 DC

28 VDC BUS 1 - Sect 2

Normal power – DC bus 1

- **28 VDC GND SVCE BUS 1**
- 28 VDC SERVICE OUTLETS
- AIR/GND SYS 1
- AIRCO PACK CONT LEFT DC
- ANTI SKID OUTBOARD
- AUTOBRAKE BITE CONT 1
- AUTOSLAT DC 1
- BLEED AIR VALVE LEFT

B737NG POWER SOURCES

- BLEED AIR XDCR LEFT
- CAPT PROBE IND
- CMU / ACARS DC
- DC BUS 1 INDICATION
- ELT
- ENG 2 HYDR PUMP DEPRESS VALVE
- EQUIP COOL SPLY FAN COW ALT
- FLAP LOAD RELIEF
- FLAP SHUT OFF VALVE
- FLIGHT CONT SHUT OFF VALVE CONT
- FSEU DC 1
- FUEL CTR TNK L AUTO SHUTOFF VLVS
- FUEL QUANTITY TANK 1
- LDG XFR VALVE PIMARY
- LDG XFR VALVE SECONDARY
- MASTER CAUTION ANN BUS 1
- MASTER DIM BUS 1
- O'WING EXIT FLIGHT LOCK LEFT
- PRESS CONTROL AUTO 1
- PSEU PRIMARY
- PTU VALVE CONT 1
- PTU VALVE CONT 2
- RAM AIR CONT LEFT

- AIRCO PACK CONT RIGHT DC
- AIRCO TEMP INDICATION
- ATC ANT SWITCH
- AUTO SPEED BRAKE
- AUTOBRAKE BITE CONT 2
- AUTOSLAT DC 2
- BLEED AIR VALVE RIGHT
- BLEED AIR XDCR RIGHT
- CAPT INTPH POWER DC 2
- COCKPIT DOOR LOCK
- LOWER DISPLAY UNIT
- DC BUS 2 INDICATION
- DEU 2 PRIMARY
- ELEVATOR TABE VALVE RIGHT
- ENG 1 HYDR PUMP DEPRESS VALVE
- ENG 2 RUN/PWR
- ENG 2 THRUST REVERSER IND
- EQUIP COOL SPLY FAN CONT NORM
- EXHAUST FAN CONT ALTERNATE
- F/O'S EFIS CONT PANEL
- F/O'S INBOARD DISPLAY
- F/O'S OUTBOARD DISPLAY
- FCC B DC
- FLIGHT CONT SHUTOFF VALVE CONT
- FMC XFR
- F/O'S INTERPHONE PWR DC 2
- F/O'S PROBE IND
- FORCE FIGHT MONITOR
- FSEU DC 2
- FUEL CTR TNKR AUTO SHUTOFF VLVS
- FUEL SHUTOFF VALVE PWR PACK
- FWD AIRSTAIR DOOR
- FWD AIRSTAIR CONTROL NORMAL
- MACH TRIM B DC
- MACH WARNING SYSTEM 2
- MASTER DIM BUS 2
- NAV SENSOR DC 2
- O'WING EXIT FLIHGT LOCK RIGHT
- PRESS CONTROL AUTO 2

28 VDC BUS 2 - Sect 1

Normal power – DC bus 2

- AUT0THROTTLE DC 2
- CARGO FIRE DETECTOR AFT B
- CARGO FIRE DETECTOR FWD B
- EMERG FLASHLIGHT CHARGER
- ENG 2 ANTI ICE CONTROL
- ENG 2 COWL ANTI ICE VALVE
- LOW FLOW DETECT SUPPLY
- PAX CALL RIGHT
- VHF COMM 3
- VOICE REC RELAY
- WINDSHIELD WIPER RIGHT

28 VDC - STANDBY BUS - Sect 1

Normal power – TR1
Alternate power – Hot BB

- CAPT EFIS CONT PANEL
- CAPT INBOARD DISPLAY
- CAPT OUTBOARD DISPLAY

28 VDC BUS 2 - Sect 2

Normal power – DC bus 2

- AFCS B ENGAGE INTERLOCK
- AFCS B RUDDER DC (Cat IIIb)
- AIR/GND RELAY

B737NG POWER SOURCES

- UPPER DISPLAY UNIT
- DEU 1 PRIMARY
- ENG 1 THRUST REVERSER CONTROL
- ENG 1 THRUST REVERSER INTERLOCK
- ENG 1 THRUST REVERSER SYNC LOCK
- INSTR XFR
- MACH WARNING SYS 1
- NAV SENSOR DC 1
- SMYD COMP 1 DC
- STBY ALT/MASI VIBRATOR
- STICK SHAKER LEFT
- VHF COMM 1

28 VDC - STANDBY BUS -Sect 2

Normal power – TR1
Alternate power – Hot BB

- DC INDICATION STBY BUS
- GENERATOR CONTROL UNIT 2

28 VDC - BAT BUS

Normal power – TR3
Alternate power – Battery

- AIR CONDITION O'HEAT
- **BATT BUS SEC 1**
- **BATT BUS SEC 2**
- **BATT BUS SEC 3**
- ENT PA SYS BAT
- EXHAUSTVALVE RECONFIG CONT
- ISFD

28 VDC - BAT BUS - Sect 1

Power – Battery bus

- ENG 1 AND WING ANTI ICE CONTROL
- ENG 1 START LEVER CHAN A
- ENG 1 START LEVER CHAN B
- ENG 1 START VALVE
- OXYGEN INDICATION
- OXYGEN MANUAL CONTROL
- PAX OXYGEN LEFT
- PAX OXYGEN RIGHT
- STBY ATT IND

28 VDC - BAT BUS - Sect 2

Power – Battery bus

- APU FIRE DETECTION
- BATT BUS INDICATION
- BRAKE PRESS IND
- CAPT INTPH POWER BAT
- DUCT O'HEAT AFT CABIN
- DUCT O'HEAT FLT DECK
- DUCT O'HEAT FWD CABIN
- ENG 1 FIRE DETECTION
- ENG 1 HYDRAULIC SYSTEM SHUTOFF VALVE
- ENG 2 FIRE DETECTION
- ENG 2 HYDRAULIC SYSTEM SHUTOFF VALVE
- ENG 2 START VALVE
- ENG 2 THRUST REVERSER CONTROL
- ENG 2 THRUST REVERSER INTERLOCK
- ENG 2 THRUST REVERSER SYNC LOCK
- ENG 2 START LEVER CHAN A
- RAM AIR MOD CONT R
- RECIRC FAN R CONT
- RUDDER AUTHORITY LIMITER
- SMYD COMP 2 DC
- SPOILER SHUTOFF VALVE
- STAB TRIM CONTROL
- STICK SHAKER RIGHT
- TRIM AIR PRESS
- VHF COMM 2
- VIDEO CONT CENTER DC
- ENG 2 START LEVER CHAN B
- EXHAUST VALVE CONT
- F/O'S INTERPHONE PWR BAT
- GENERATOR 1 DISC
- GENERATOR 2 DISC
- GENERATOR CONTROL UNIT 1
- L AIRCO PACK VALVE CONT
- R AIRCO PACK VALVE CONT
- MASTER FIRE WARNING & CONTROL
- MCP DC 2
- PA AMP BAT
- PACK/BLEED AIR O'HEAT L & R
- PRESS CONTROL INDICATION
- PRESS CONTROL MANUAL
- STBY RUDDER SHUTOFF VALVE